

# MotorGuide REPAIR PARTS

Model: **POWER plus**  
**T52V**

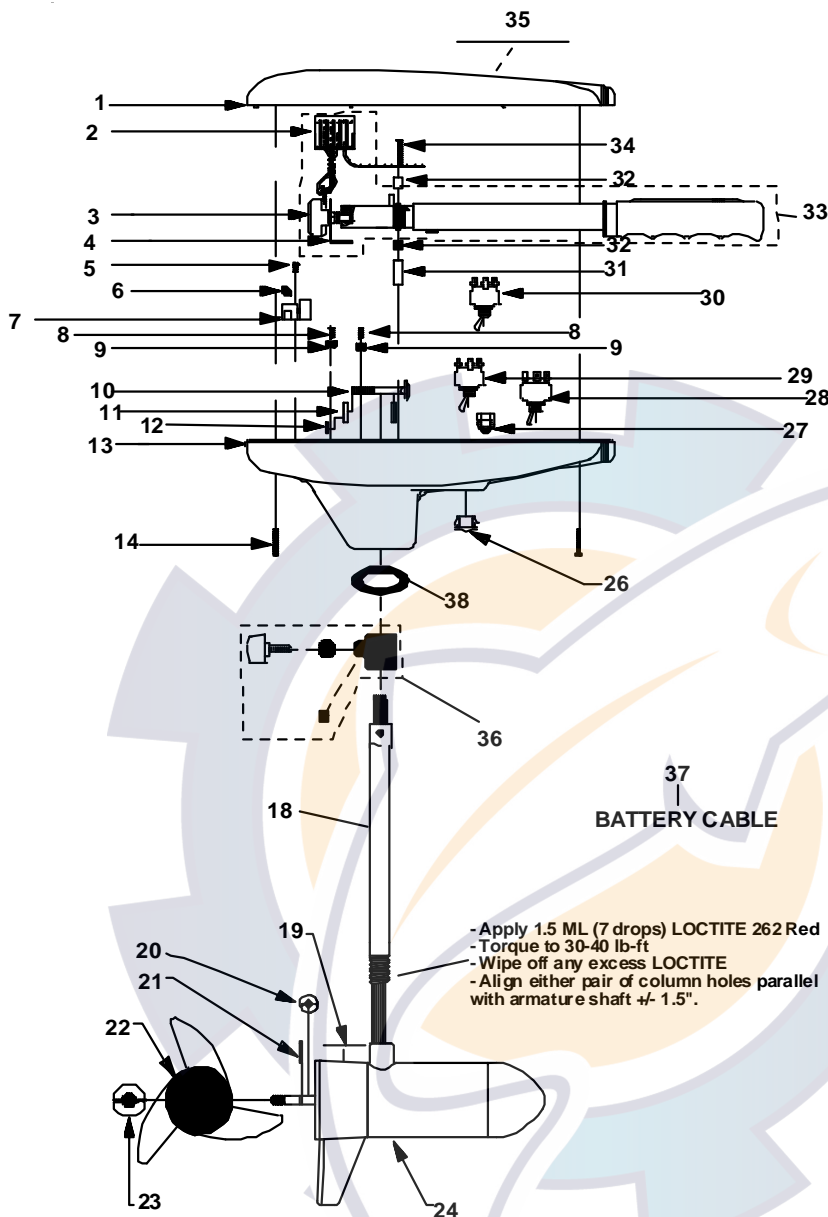

**SPECIFICATIONS:**

Year of Intro 1998  
 Thrust 52LBS  
 Volts 12VDC  
 Amp Draw 0 to 48 amps  
 Mount 09 Transom  
 Speeds Variable

**QUICK REFERENCE PARTS GUIDE:**

FOR/REV Switch FP153-06  
 DA Board JF157-03  
 MOSFET JF096-07  
 Motor Seal Kit 6220

**PARTS ORDERING & TECH ASSISTANCE**

MotorGuide Consumer Relations  
 Phone 918-831-6989  
 Fax 800-982-8093

**Send Returned Goods to:**

MotorGuide  
 605 Hwy 12 West  
 Starkville, MS 39760

*Returned Goods must be accompanied with a Returned Goods Authorization. Contact MotorGuide Consumer Relations to obtain RGA.*

KEY	DESCRIPTION	PART #	KEY	DESCRIPTION	PART #
1	TOP HOUSING COVER BLACK	AT053-10	24	H/O MOTOR	CF397-05
2	AMP CONNECTOR	AP029-01	25	DEPTH ADJUSTMENT COLLAR	AR051-01
3	POTENTIOMETER	AP168-02	26	HOLE PLUG	FP021-03
4	POT BRACKET	AT155-03	27	GROMMET	GR019-03
5	SELF TAPPING SCREW	AF141-01	28	TOGGLE SWITCH 3 POSITIONS	FP153-05
6	INSULATING SLEEVE	AT080-01	29	FWD/REV SWITCH 2 POSITIONS	FP153-06
7	12 VOLT DURA AMP BOARD	JF157-03	30		
8	#10 X 1/2" SCREW	GR133-01	31	WIRE BRACKET	AT155-04
9	TERMINAL BLOCK	FT160-01	32	RETAINER CLAMP	AR036-01
10	BOLT	TT134-01	33	HANDLE ASY	AT372-03
11	CURVED WASHER	TT171-04	34	8 X 1-3/8 SCREW	AR133-01
12	NYLON LOCK NUT	XT098-02	35	NOMENCLATURE	ET056-07
13	T/H BASE BLACK	AR004-14	36	DEPTH COLLAR ASY	AR158-01
14	SCREW #8 X 1"	LF141-04	37	BATTERY CABLE	BT328-03
15	BAR KNOB DEPTH ADJUSTMENT	AR082-02	38	COLUMN SEAL	AT079-01
16	COLUMN CLAMP WASHER	AR171-01			
17	COLUMN SUPPORT NUT	FR098-01			
18	COLUMN 36"	TT049-05			
	COLUMN 42"	TT049-06			
	COLUMN 50"	FR049-13			
19	LOWER UNIT DECAL	ET060-04			
20	MONOFILAMENT WASHER	AR175-01			
21	PROP DRIVE PIN	BR102-01			
22	PROP/3 BLADE	AF124-10			
	PROP/2 BLADE	AF124-05			
23	PROP NUT	AR099-01			

LOWER UNIT BREAKDOWN

Model:  
**T52V**

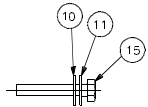
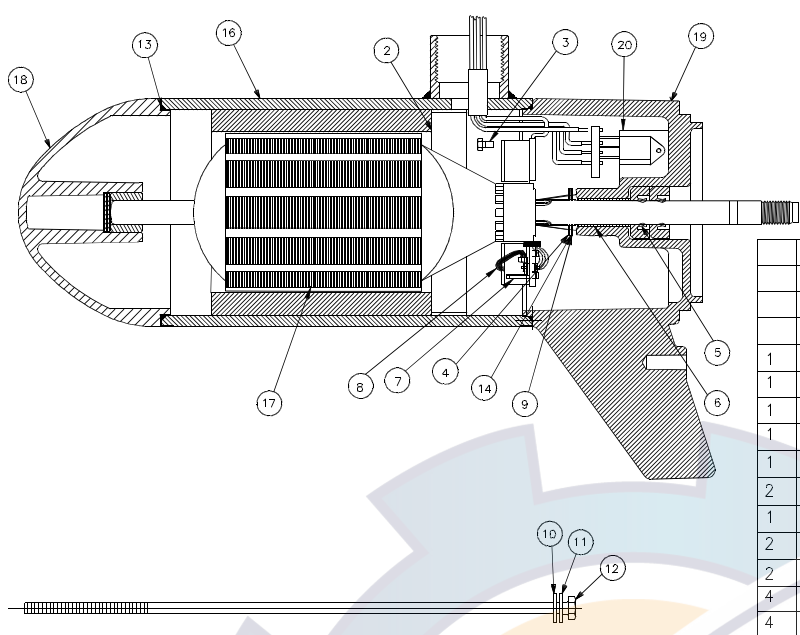

NOTE-TORQUE THUR BOLT, PART No. MR218-02 AND DURA AMP SCREW PART No. MR229-01, TO 35-40 INCH POUNDS

NO. REQ'D	ITEM NO.	DESCRIPTION	PART NO.
		REPAIR KIT(INCLUDES ALL*)	7317
1	20	DURA AMP MODULE	JF096-07
1	19	COMM CAP LESS MOSFET & BRUSH ASS'Y	JF3205-04DSAW
1	18	NOSE CAP S/A	JF3212-01BSAW
1	17	ARMATURE 3.5"	CF3207-01
1	16	HOUSING ASS'Y	JF3210-01BSAW
2	15	DURA AMP SCREW	MR229-01
1	14	WASHER	* MR227-01
2	13	"O"-RING SEAL	* MR217-01
2	12	THRU BOLT	MR218-02
4	11	THRU BOLT WASHER	* MR216-01
4	10	STATIC SEAL	* MR222-01
1	9	NYLATRON WASHER	* MR226-01
1	8	BRUSH ASS'Y-LESS SPRING	JF3201-03
2	7	BRUSH SPRINGS	* MR214-02
1	6	BEARING	* MR206-01
2	5	SHAFT SEAL	* MR223-01
1	4	"E" RING	MR219-02
2	3	BRUSH CARD SCREW	MR228-01
1	2	RETAINER	JF233-01
1	1	3.5"-41#-D.A. MOTOR 50"	CF397-05

WIRING

12V OR 24V D.A. WIRING DIAGRAM

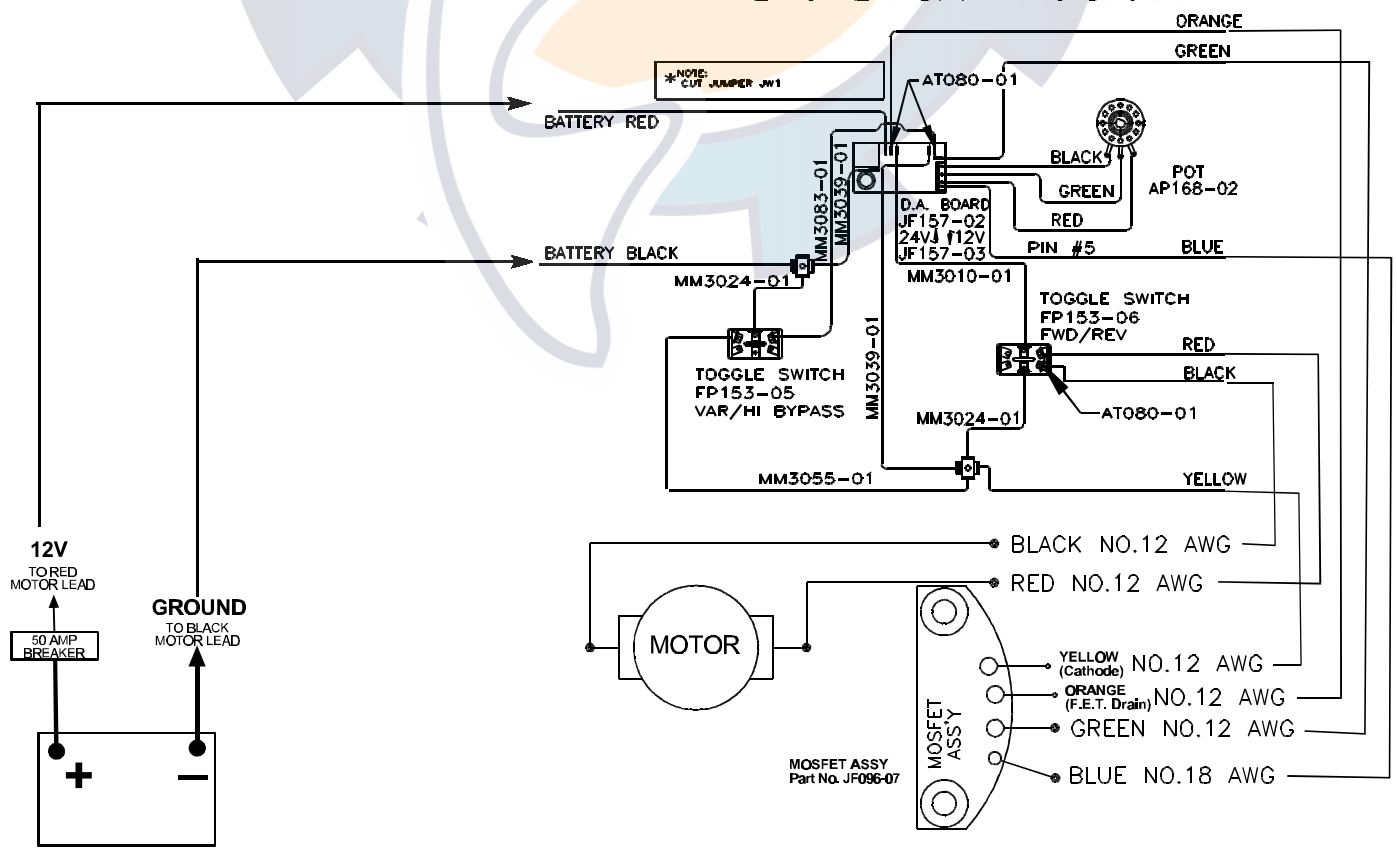

ASSEMBLE AT STATIC FREE WORK STATION!